

PRODUCT BRIEF

High Performance Computing (HPC) and Artificial Intelligence (AI)
Intel® Server System S9200WK product family featuring Intel® Xeon®
Platinum 9200 processors



Density Optimized System Solution Providing Leadership Performance for HPC and AI



Performance Optimized for Compute Density

The Intel® Server System S9200WK product family is a purpose built, performance-optimized data center block ideal for use in High Performance Computing and Artificial Intelligence applications. Designed for Intel® Xeon® Platinum 9200 series processors, with up to 24 DDR4 DIMM slots per compute module, the S9200WK family maximizes processor and memory bandwidth to provide leadership performance for the most demanding compute use requirements.

Intel® Xeon® Platinum 9200 Processors Advanced Performance

- Leadership processor performance per socket with Intel's highest core count, Intel® Xeon® Platinum 9200 processors
- Double the memory bandwidth for memory-intensive workloads with 12 memory channels per processor, 24 memory channels per compute module
- New Intel® Deep Learning Boost Instructions for data analytics greatly accelerates inference performance
- Multi-chip packaging optimized for density and performance

Density Optimized 2U Rack Server with Air-Cooled and Liquid-Cooled Options

- Up to four compute modules per 2U chassis which can support multiple compute module types in a single chassis
- Two-processor compute module design with advanced cooling technology for high flow rate air- or liquids cooled for processors, VRs, DIMMs, and memory VRs for high heat capture ratio
- Up to 350-W processor TDP for high performance workloads in a 2U air-cooled chassis; up to 400-W processor TDP with liquid-cooled versions
- Up to two x16 PCIe slots in 1U compute modules; up to four x16 PCIe slots in 2U compute modules for network expansion options
- Support for 2x M.2 SATA/NVMe* storage devices per 1U compute module; up to 2x M.2 SATA/NVMe and 2x U.2 NVMe storage devices per 2U compute module
- Hot-swappable compute modules, storage¹, fans, and power supplies

Built with Intel Quality, Reliability and Performance

Intel® Server Products are backed by Intel's design excellence and manufacturing expertise to deliver processing power with high levels of flexibility, manageability and reliability. Product and design quality is paired with 3-year standard warranties and robust technical and incident resolution support to ensure customer satisfaction.

Accelerating Time to Market with Innovative Data Center Solutions

The S9200WK product family is the highest performance member of Intel® Data Center Blocks. These fully validated, unbranded server systems include Intel’s latest data center technology— already optimized to work better together—allowing partners to accelerate time to market with reliable data center solutions. The process of configuring and validating the hardware components of solutions that are tuned to meet specific customer requirements is a complex and resource intensive process. Intel Data Center Blocks based on the S9200WK product family reduce this complexity, making it easier to build innovative server solutions that can support the demands of today’s data center workloads.

Highly Integrated, High Density Compute Solution

The Intel Server System S9200WK Data Center Block can be configured to support a wide range of memory, storage, and I/O options. Solutions are configured using Intel Xeon Platinum 9200 processors, Intel® Server System S9200WK Compute Modules, and Intel® Server Chassis FC2000. The Intel Server Chassis FC2000 family allows flexible configuration of different functionality compute modules in a single chassis further extending the benefits of Intel Server System S9200WK Data Center Blocks. This allows a single data center block to address both compute and service node functionality simultaneously, reducing cost and increasing functionality.



Intel® Server System S9200WK Data Center Block Technical Specifications	
Form Factor	2U rack enclosure; up to four independent warm-swap compute modules
CPU	Intel® Xeon® Platinum 9200 processors with up to 56 cores
Memory	DDR4 2933 MT/s DIMMs, up to 96x DIMMs per DCB (24 DIMMs per compute module) @ 1DPC Supports 8 GB to 128 GB DIMM options, number and capacity configurable
Storage	Up to 8x M.2 SSDs per DCB with 1U compute modules; Up to 4x M.2 SSDs & 4x hot-swap U.2 NVMe* SSDs with 2U Compute Modules M.2 and U.2 number and capacity configurable
Power Supply	3x hot-swap CRPS 2100 W (Platinum) or 1600 W (Titanium) PSUs
Ethernet	Integrated 1Gbase-T RJ45 (two ports per compute module), optional shared 1Gbase-T RJ45 management port chassis card
Cooling	Available with high flow rate air-cooling or integrated liquid-cooling options
I/O	2 x16 Gen3 PCIe* slots per 1U compute module; 4 x16 Gen3 PCIe slots per 2U compute module for high-speed networking support
Manageability	Dedicated, consolidated Management Module
Security & Serviceability	TPM 2.0 (optional); hot-swap/redundant fans, and PSUs; light path diagnostic LEDs

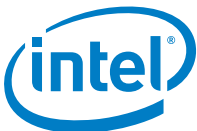



Intel® Xeon® Platinum 9200 Processors (Intel® Data Center Block Component)

	Cores	Base Frequency	Max Turbo Frequency	L3 Cache	# of Intel® UPI Links	Power
9282	56	2.6 GHz	3.8 GHz	77 MB	4	400 W
9242	48	2.3 GHz	3.8 GHz	71.5 MB	4	350 W
9222	32	2.3 GHz	3.7 GHz	71.5 MB	4	250 W
9221	32	2.3 GHz	3.7 GHz	71.5 MB	4	250 W

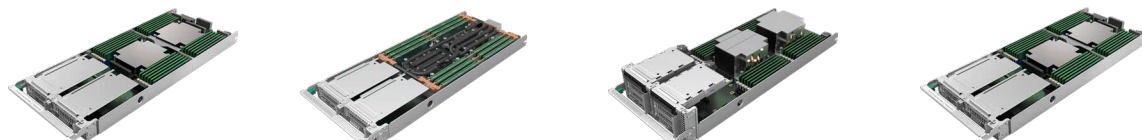

Intel® Server System S9200WK Compute Modules (Intel® Data Center Block Component)

Component	1U half-width air-cooled compute module	1U half-width liquid-cooled compute module	2U half-width air-cooled compute module	2U half-width liquid-cooled compute module
Processor	Intel® Xeon® Platinum 9200 processors with up to 32 cores 250 W TDP	Intel® Xeon® Platinum 9200 processors with up to 56 cores 400 W TDP	Intel® Xeon® Platinum 9200 processors with up to 48 cores 350 W TDP	
Memory	DDR4 2933 MT/s DIMMs, up to 24 DIMMs per compute module @ 1DPC; Supports 8-GB to 128-GB DIMM options, number and capacity configurable			
Storage	Two M.2 SATA/NVMe* SSDs (80 or 110 mm)		Two M.2 SATA/NVMe SSDs (80 or 110 mm) and two U.2 NVMe hot-swap SSDs, optional RAID 0 and 1 support available on U.2 SSDs	
DCB Configuration	2U/4N air-cooled	2U/4N liquid-cooled	2U/2N air-cooled	2U/2N liquid-cooled
I/O	Two integrated 1Gbase-T RJ45 & 2 x16 Gen3 PCIe* slots		Two integrated 1Gbase-T RJ45 & 4 x16 Gen3 PCIe slots	
Debug Support	Dedicated port for VGA, serial, & 2 USB 2.0 port connectivity			
Cooling	High-flow air-cooling	Direct-to-chip liquid-cooling for processors, VRs, DIMMs, and memory VRs	High-flow air-cooling	Direct-to-chip liquid-cooling for processors, VRs, DIMMs, and memory VRs



Intel® Server Chassis FC2000 (Intel® Data Center Block Component)

Component	2U front I/O standard-width air-cooled chassis with included rail-kit	2U front I/O standard-width liquid-cooled chassis with included rail-kit
Supported Configurations	Four 1U half-width compute modules; two 2U half-width compute modules; two 1U half-width compute modules and one 2U half-width compute module	
Cooling	Three 60-mm fans and two 80-mm fans	Three 60-mm fans and integrated liquid-cooling manifold (SCG06 external connectors, CGD03 internal connectors)
Power Supplies	Three hot-swap CRPS 1600-W (Titanium) or 2100-W (Platinum) PSUs	Three hot-swap CRPS 2100-W (Platinum) PSUs
Options	Optional shared 1GBase-T RJ45 management port chassis card	



Intel® Server System S9200WK Production Components	
Product Code	Description
S9256WK1HLC ²	Intel® Compute Module S9200WK 1U Half-Width Compute Node Liquid-Cooled CPU 56C
S9248WK1HLC ²	Intel® Compute Module S9200WK 1U Half-Width Compute Node Liquid-Cooled CPU 48C
S9232WK1HLC ²	Intel® Compute Module S9200WK 1U Half-Width Compute Node Liquid-Cooled CPU 32C
S9232WK1HAC ²	Intel® Compute Module S9200WK 1U Half-Width Compute Node Air-Cooled CPU 32C
S9248WK2HLC ²	Intel® Compute Module S9200WK 2U Half-Width Service Node Liquid-Cooled CPU 48C
S9232WK2HLC ²	Intel® Compute Module S9200WK 2U Half-Width Service Node Liquid-Cooled CPU 32C
S9248WK2HAC ²	Intel® Compute Module S9200WK 2U Half-Width Service Node Air-Cooled CPU 48C
S9232WK2HAC ²	Intel® Compute Module S9200WK 2U Half-Width Service Node Air-Cooled CPU 32C
FC2HLC21W3 ²	Intel® Server Chassis FC2000 Half-Width Configuration Liquid-Cooled (2100W)
FC2HAC21W3 ²	Intel® Server Chassis FC2000 Half-Width Configuration Air-Cooled (2100W)
FC2HAC16W3 ²	Intel® Server Chassis FC2000 Half-Width Configuration Air-Cooled (1600W)

² These systems and system components can only be purchased as part of an Intel® Data Center Block or as spare components.

Intel® Server System S9200WK Spares and Accessories	
Product Code	Description
AXXCONNTDBG	Intel® Compute Module S9200WK multi-connector debug dongle
AXXFCEMP	Intel® Server Chassis FC2000 EMP module
AXXFC1UBLANK	Intel Server Chassis FC2000 1U compute module blank
FXXWK1URISER	Intel Compute Module S9200WK 1U PCIe* riser card
FXXWK2URISER	Intel Compute Module S9200WK 2U PCIe riser card
FXXWKHS	Intel Compute Module S9200WK air-cooled heat sink, single
FXXWK1UHSF	Intel Compute Module S9200WK air-cooled 1U heat sink front, single
FXXWK1UHSB	Intel Compute Module S9200WK air-cooled 1U heat sink back, single
FXXWKLCLP	Intel Compute Module S9200WK liquid-cooling loop
FXXWKM2HS	Intel Compute Module S9200WK M.2 heat sink assembly
FXXWKLCDMCLP	Intel Compute Module S9200WK liquid-cooling loop DIMM clip
FXXWKLCDMTM	Intel Compute Module S9200WK liquid-cooling loop DIMM TIMM
FCXX2100CRPS	Intel Server Chassis FC2000 2100-W PSU
FCXX60MMFAN	Intel Server Chassis FC2000 60-mm fan
FCXX80MMFAN	Intel Server Chassis FC2000 80-mm fan
FCXXLCMANFLD	Intel Server Chassis FC2000 liquid-cooling manifold
FCXXPDBASSMBL	Intel Server Chassis FC2000 PDB assembly
FCXX1USPPRT	Intel Server Chassis FC2000 1U internal rail kit
FCXXRAILKIT	Intel Server Chassis FC2000 external rail kit

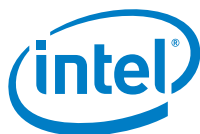

Footnotes:

1: 2U compute modules include hot-swap U.2 SSDs. M.2 storage in all compute modules does not support hot-swap.

Intel technologies' features and benefits depend on system configuration and may require enabled hardware, software, or service activation. Performance varies depending on system configuration. No computer system can be absolutely secure. Check with your system manufacturer or retailer or learn more at [intel.com](https://www.intel.com).

Cost reduction scenarios described are intended as examples of how a given Intel-based product, in the specified circumstances and configurations, may affect future costs and provide cost savings. Circumstances will vary. Intel does not guarantee any costs or cost reduction. Intel, the Intel logo, and Xeon are trademarks of Intel Corporation in the U.S. and/or other countries.

*Other names and brands may be claimed as the property of others.

Intel® Omni-Path Fabric Edge Switches 100 Series

48 and 24 port edge switches (100 Gbps per port)



Intel® Omni-Path Fabric Edge Switches, an element of the Intel® Scalable System Framework, are part of an end-to-end product family for HPC fabrics that delivers high performance with breakthrough value. Intel® Omni-Path Architecture (Intel® OPA) builds on proven technologies from Intel® True Scale Architecture, the Cray Aries* interconnect, and open source software to provide an evolutionary on-ramp to revolutionary new fabric capabilities.

Higher Performance at Lower Cost

Intel® Omni-Path Edge Switches deliver 100 Gbps port bandwidth with latency that stays low even at extreme scale. Second generation Intel fabric switch silicon, with market leading 48 port radix, these switches can lower fabric acquisition costs by as much as 50 percent, while simultaneously reducing space and power requirements.ⁱ With these savings, you can potentially achieve higher total cluster performance within the same hardware budget to expand and accelerate your research.

Flexible Fabrics at Every Scale

Intel® Omni-Path Fabric Edge Switches support HPC clusters of all sizes, from entry-level systems to supercomputers with tens of thousands of server nodes. You can use these switches in

The Right Fabric for HPC

Key Benefits

Highly-integrated design reduces space, power, and cost

- 48 ports, 1U chassis
- 24 ports, 1U chassis

Optimized for high message rates and low end-to-end latency

Simple generational upgrades, with:

- Binary compatible applications
- FastFabric tools for easy installation
- All open source software

Key Features

Up to 1.2 terabytes of aggregate bandwidth

Out of band fabric management (optional)

Redundant power (optional)

Redundant cooling

Reversible air flow

Next-generation fabric innovations

- Packet Integrity Protection (PIP)
- Traffic Flow Optimization (TFO)
- Dynamic Lane Scaling (DLS)
- New 8K and 10K MTUs for improved storage efficiency

combination with Intel® Omni-Path Director Class Switches to build low-latency, multi-tier fabrics with an exceptional set of features for high-speed networking.

High Availability

Intel® Omni-Path Fabric Edge Switches provide integrated support for high availability with advanced features such as power, component-level diagnostics and alarming, and out-of-band management. Innovative features take fabric resilience and availability to new heights without sacrificing performance. Packet Integrity Protection (PIP), for example, provides high packet reliability with latency-free error checking and link-level recovery. Dynamic Lane Scaling (DLS) maintains 75 percent of link bandwidth if a physical lane fails, so HPC workloads can complete gracefully to keep project efforts on track.

SWITCH SPECIFICATIONS

- Based on Intel® Omni-Path Switch Silicon 100 Series 48 Port ASIC
- 100 Gbps per port bidirectional
- Virtual lanes: Configurable from one to eight VLs plus one management VL
- Configurable MTU size of 2 KB, 4 KB, 8 KB, or 10KB
- Maximum multicast table size: 8192 entries
- Maximum unicast table size: 49151 entries
- Supports QSFP28 Quad Small Form Factor Pluggable cabling
- Passive copper or active fiber cables

Management Features

- Management Card (Optional)
- Built-in Fabric Manager
- Subnet Management Agent (SMA)
- Performance Management Agent (PMA)
- Enables Command Line Interface and Chassis Management GUI through 10/100/1000 Base-T Ethernet
- Enables Serial Console through USB Serial Port
- Supports Embedded Subnet Manager (ESM) and Performance Manager (PM)
- Enables Network Time Protocol (NTP), SNMP/MIBs, and LDAP
- FastFabric Toolset
- Fabric Management GUI

LED status

- Twenty-four (24) or forty-eight (48) link status indicators, one per QSFP28 port (Green)
- Two (2) Ethernet indicators (Off = 10; Green = 100; Orange = 1G)
- Two (2) Chassis indicators (Green – Status; Amber - Attention)
- Two (2) Power Supply, one per supply (Green)
- One (1) Q7 Management Installed, (Green - Installed)
- One (1) External Management Capable, (Green – One or more ports can be directly connected to a Fabric Manager)
- Airflow direction (Green – front-to-back airflow)

FEATURE	100SWE48Q	100SWE48U	100SWE24Q	100SWE24U
100Gb ports	48	48	24	24
Total System Bandwidth (bi-dir)	1.2TB/s	1.2TB/s	.6 TB/s	.6 TB/s
Dimensions (w x h x d)	17.3"x1.72"x17.15"	17.3"x1.72"x17.15"	17.3"x1.72"x17.15"	17.3"x1.72"x17.15"
Reversible Fan Modules	1	1	1	1
Mgmt. Modules	1	0	1	0
Power Supplies (Fixed) Min / AC	1/2	1/2	1/2	1/2
Power (Typ./Max) Input	189/238 W (Copper)	189/238 W (Copper)	146/179 W (Copper)	146/179 W (Copper)
100-240 VAC 50-60 Hz Optical	356/408 W (All Optical)	356/408 W (All Optical)	231/264 W (All Optical)	231/264 W (All Optical)
Power w/ Max 3W QSFP				
Weight - Fully Loaded	6.7kg	6.7kg	6.2kg	6.2kg

INTEL SKU	INTEL MM#	DESCRIPTION
100SWE48QF2	948588	Intel® Omni-Path Edge Switch 100 Series 48 Port Managed Forward 2 PSU 100SWE48QF2
100SWE48UF2	948678	Intel® Omni-Path Edge Switch 100 Series 48 Port Forward 2 PSU 100SWE48UF2
100SWE24QF2	945654	Intel® Omni-Path Edge Switch 100 Series 24 Port Managed Forward 2 PSU 100SWE24QF2
100SWE24UF2	945655	Intel® Omni-Path Edge Switch 100 Series 24 Port Forward 2 PSU 100SWE24UF2
100SWE48QF1	945662	Intel® Omni-Path Edge Switch 100 Series 48 Port Managed Forward 1 PSU 100SWE48QF1
100SWE48UF1	945663	Intel® Omni-Path Edge Switch 100 Series 48 Port Forward 1 PSU 100SWE48UF1
100SWE24QF1	945664	Intel® Omni-Path Edge Switch 100 Series 24 Port Managed Forward 1 PSU 100SWE24QF1
100SWE24UR1	945669	Intel® Omni-Path Edge Switch 100 Series 24 Port Reverse 1 PSU 100SWE24UR1
100SWEQ7CN1	945775	Intel® Omni-Path Edge Switch Management Card 100 Series 100SWEQ7CN1
100SWEIKIT1	945820	Intel® Omni-Path Edge Switch Installation Kit 100 Series 100SWEIKIT1

Compliance

US/Canada

- FCC Part 15, Subpart B, Class A
- CAN ICES-3 (A)

Europe

- CISPR22
- CISPR32/EN55032
- EN55024
- EN61000-3-2
- EN61000-3-3

Japan

- VCCI, Class A

New Zealand/Australia

- AS/NZS CISPR 22, Class A

Korea

- RRA/KC (KN22, KN24), Class A

Taiwan

- BSMI (CNS 13438), Class A

Customs Union: Russia, Belarus and Kazakhstan

- GOST R IEC 60950-1
- GOST R 51318.22
- GOST 30805.24
- GOST R 51317.3.2 (Section 6, 7)
- GOST R 51317.3.3

Agency Approvals – Safety (Planned)

US/Canada

- TUV NRTL: UL 60950-1, CSA 22.1.No. 60950-1

Europe

- TUV SUD EN60950-1

International

- CB Scheme: IEC 60950-1

RoHS/REACH

- Complies with RoHS II Directive 2011/65/EU of the European Parliament
- Complies with REACH Regulation (EC) No 1907/2006

Acoustics

- Less than 7.0 Bels

Environmental Specifications

Temperature

- Operating: 0° to 40° C
- Storage: -40° to 70° C

Humidity

- Operating: 5% to 85% non-condensing
- Storage: 5% to 95% non-condensing

Altitude

- Operating: 0 – 10,000 feet (Temperature Derating 1C/175M above 900M)
- Storage: 0 – 40,000 feet

Shock

- Unpackaged: Half-sine, 2g 11ms 300 pulses total
- Packaged: 36" in free fall drop

Vibration

- UnPackaged: 5-500 Hz, 2.2 g RMS random
- Packaged: 5-500 Hz, 1.09 g RMS random

Airflow - Reversible (Variable Speed Fans)

- 70 CFM maximum at 40°C



INFORMATION IN THIS DOCUMENT IS PROVIDED IN CONNECTION WITH INTEL PRODUCTS. NO LICENSE, EXPRESS OR IMPLIED, BY ESTOPPEL OR OTHERWISE, TO ANY INTELLECTUAL PROPERTY RIGHTS IS GRANTED BY THIS DOCUMENT. EXCEPT AS PROVIDED IN INTEL'S TERMS AND CONDITIONS OF SALE FOR SUCH PRODUCTS, INTEL ASSUMES NO LIABILITY WHATSOEVER AND INTEL DISCLAIMS ANY EXPRESS OR IMPLIED WARRANTY, RELATING TO SALE AND/OR USE OF INTEL PRODUCTS INCLUDING LIABILITY OR WARRANTIES RELATING TO FITNESS FOR A PARTICULAR PURPOSE, MERCHANTABILITY, OR INFRINGEMENT OF ANY PATENT, COPYRIGHT OR OTHER INTELLECTUAL PROPERTY RIGHT.

Intel may make changes to specifications and product descriptions at any time, without notice. Designers must not rely on the absence or characteristics of any features or instructions marked "reserved" or "undefined". Intel reserves these for future definition and shall have no responsibility whatsoever for conflicts or incompatibilities arising from future changes to them. The information here is subject to change without notice. Do not finalize a design with this information.

The products described in this document may contain design defects or errors known as errata which may cause the product to deviate from published specifications. Current characterized errata are available on request.

Contact your local Intel sales office or your distributor to obtain the latest specifications and before placing your product order.

Copies of documents which have an order number and are referenced in this document, or other Intel literature, may be obtained by calling 1-800-548-4725, or go to:
<http://www.intel.com/design/literature.htm>

Intel® and the Intel logo are trademarks or registered trademarks of Intel Corporation or its subsidiaries in the United States and other countries.

*Other names and brands may be claimed as the property of others.

Intel technologies' features and benefits depend on system configuration and may require enabled hardware, software or service activation. Learn more at Intel.com, or from the OEM or retailer.

Software and workloads used in performance tests may have been optimized for performance only on Intel® microprocessors

Copyright © 2016, Intel Corporation. All rights reserved..

ⁱ Internal cost analysis based on a 256-node to 2048-node clusters configured with Mellanox* FDR and EDR InfiniBand* products. Mellanox component pricing from kernelsoftware.com Prices as of November 3, 2015. Compute node pricing based on Dell PowerEdge R730 server from www.dell.com. Prices as of May 26, 2015. Intel® OPA (x8) utilizes a 2-1 over-subscribed Fabric. Intel® OPA pricing based on estimated reseller pricing using projected Intel MSRP pricing on day of launch.

Mouser Electronics

Authorized Distributor

Click to View Pricing, Inventory, Delivery & Lifecycle Information:

[Intel:](#)

[100SWE48QF2](#) [100SWE48QF1](#) [100SWE48UFH](#) [100SWE24UF2](#) [100SWE48UF2](#) [100SWE48QFH](#) [100SWE24UF1](#)
[100SWE48UF1](#)



Product Overview

The Catalyst 2960-X and Catalyst 2960-XR family of switches are Ethernet switches to which you can connect devices such as Cisco IP Phones, Cisco Wireless Access Points, workstations, and other network devices such as servers, routers, and other switches.

Some models of the switches support stacking through the Cisco FlexStack technology. Unless otherwise noted, the term *switch* refers to a standalone switch and to a switch stack.

This chapter contains these topics:

- [Switch Models, on page 1](#)
- [Front Panel, on page 3](#)
- [Rear Panel, on page 16](#)
- [Management Options, on page 22](#)
- [Network Configurations, on page 23](#)

Switch Models

Table 1: Catalyst 2960-X Switch Models and Descriptions

Switch Model	Supported Software Image	Description
Catalyst 2960X-48FPD-L	LAN Base	48 10/100/1000 Power over Ethernet Plus (PoE+) ports (PoE budget of 740 W) and 2 small form-factor pluggable (SFP)+ module slots.
Catalyst 2960X-48LPD-L ¹	LAN Base	48 10/100/1000 PoE+ ports (PoE budget of 370 W) and 2 SFP+ module slots.
Catalyst 2960X-24PD-L ¹	LAN Base	24 10/100/1000 PoE+ ports (PoE budget of 370 W) and 2 SFP+ module slots.
Catalyst 2960X-48TD-L ¹	LAN Base	48 10/100/1000 ports and 2 SFP+ module slots.

Switch Model	Supported Software Image	Description
Catalyst 2960X-24TD-L ¹	LAN Base	24 10/100/1000 ports and 2 SFP+ module slots.
Catalyst 2960X-48FPS-L ¹	LAN Base	48 10/100/1000 PoE+ ports (PoE budget of 740 W) and 4 SFP module slots.
Catalyst 2960X-48LPS-L ¹	LAN Base	48 10/100/1000 PoE+ ports (PoE budget of 370 W) and 4 SFP module slots.
Catalyst 2960X-24PS-L ¹	LAN Base	24 10/100/1000 PoE+ ports (PoE budget of 370 W) and 4 SFP module slots.
Catalyst 2960X-48TS-L ¹	LAN Base	48 10/100/1000 ports and 4 SFP module slots.
Catalyst 2960X-24TS-L ¹	LAN Base	24 10/100/1000 ports and 4 SFP module slots
Catalyst 2960X-48TS-LL	LAN Lite	48 10/100/1000 ports and 2 SFP module slots.
Catalyst 2960X-24TS-LL	LAN Lite	24 10/100/1000 ports and 2 SFP module slots.
Catalyst 2960X-24PSQ-L	LAN Base	24 10/100/1000 (8 PoE- with PoE budget of 110 W) ports, fanless, 2 10/100/1000BaseT copper uplinks, and 2 SFP module slots.

¹ Support Cisco FlexStack technology.

² SFP+ = 10-Gigabit uplink.

³ SFP = 1-Gigabit uplink.

Table 2: Catalyst 2960-XR Switch Models and Descriptions

Switch Model	Supported Software Image	Description
Catalyst 2960XR-48FPD-I ¹	IP Lite	48 10/100/1000 PoE+ ports (PoE budget of 740 W) 2 SFP+ module slots, 1025-W power supply.
Catalyst 2960XR-48LPD-I ¹	IP Lite	48 10/100/1000 PoE+ ports (PoE budget of 370 W) 2 SFP+ module slots, 640-W power supply.
Catalyst 2960XR-24PD-I ¹	IP Lite	24 10/100/1000 PoE+ ports (PoE budget of 370 W) 2 SFP+ module slots, 640-W power supply.

Switch Model	Supported Software Image	Description
Catalyst 2960XR-48TD-I ¹	IP Lite	48 10/100/1000 and 2 SFP+ module slots, 250-W power supply.
Catalyst 2960XR-24TD-I ¹	IP Lite	24 10/100/1000 and 2 SFP+ module slots, 250-W power supply.
Catalyst 2960XR-48FPS-I ¹	IP Lite	48 10/100/1000 PoE+ ports (PoE budget of 740 W) and 4 SFP module slots, 1025-W power supply.
Catalyst 2960XR-48LPS-I ¹	IP Lite	48 10/100/1000 PoE+ ports (PoE budget of 370 W) and 4 SFP module slots, 640-W power supply.
Catalyst 2960XR-24PS-I ¹	IP Lite	24 10/100/1000 PoE+ ports (PoE budget of 370 W) and 4 SFP module slots, 640-W power supply.
Catalyst 2960XR-48TS-I ¹	IP Lite	48 10/100/1000 and 4 SFP module slots, 250-W power supply.
Catalyst 2960XR-24TS-I ¹	IP Lite	24 10/100/1000 and 4 SFP module slots, 250-W power supply.

Front Panel

This section describes the front panel components:

- 24 or 48 downlink ports of one of these types:
 - 10/100/1000
 - 10/100/1000 PoE+
- SFP ports
- USB Type A connectors
- USB mini-Type B (console) port
- Ethernet management port
- RJ-45 console port
- LEDs
- Mode button

Figure 1: Catalyst 2960X-48FPD-L Front Panel

The Catalyst 2960X-48FPD-L switch is shown here as an example. Other switches have similar components.

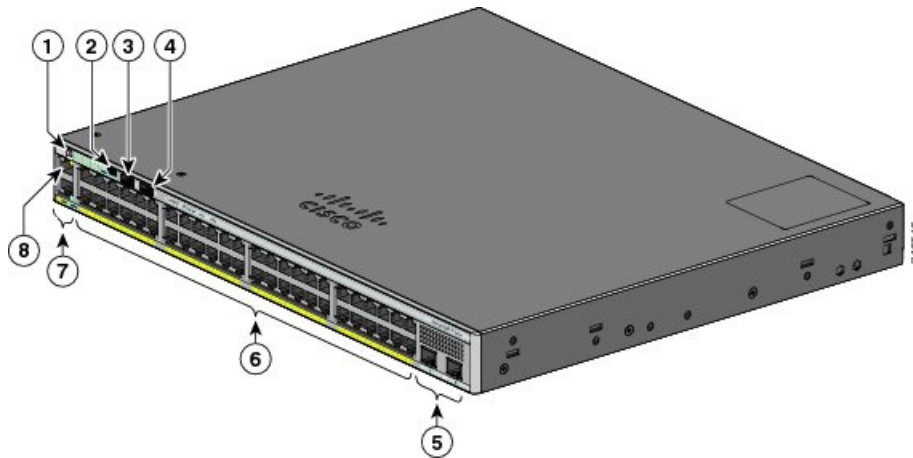

1	Mode button and switch LEDs	5	SFP module slots
2	USB mini-Type B (console) port	6	10/100/1000 PoE+ ports
3	USB Type A port	7	RJ-45 console port
4	USB Type A port	8	Ethernet management port

Figure 2: Catalyst 2960XR-48LPD-I Front Panel

The Catalyst 2960XR-48LPD-I switch is shown here as an example. Other Catalyst 2960-XR switches have

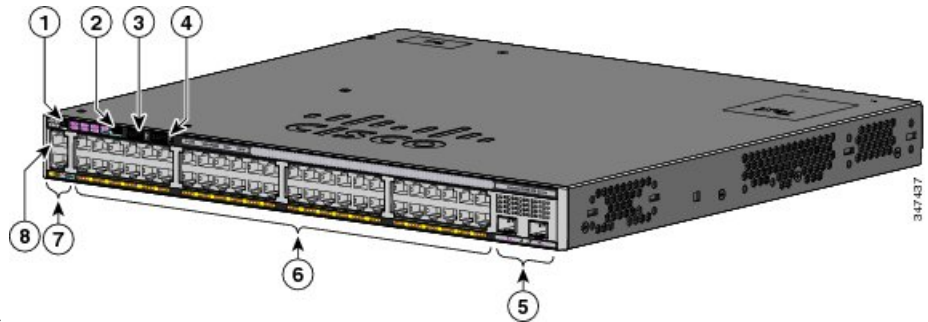

similar components.

1	Mode button and switch LEDs	5	SFP+ module slots
2	USB mini-Type B (console) port	6	10/100/1000 PoE+ ports
3	USB Type A port	7	RJ-45 console port
4	USB Type A port	8	Ethernet management port

PoE and PoE+ Ports

The ports provide PoE+ support for devices compliant with IEEE 802.3af, IEEE 802.3at, and ePoE and also provide Cisco prestandard PoE support for Cisco IP Phones and Cisco Aironet Access Points.

The maximum switch power output is either 740 W or 370 W, depending on the switch model. Intelligent power management allows flexible power allocation across all ports.

For switches with a 740 W power budget, you can budget the PoE and PoE+:

- 15.4 W of PoE output on 48 ports
- 30 W of PoE+ on 24 ports

For switches with a 370 W power budget, you can budget the PoE and PoE+:

- 15.4 W of PoE output on 24 ports
- 7.7 W of PoE output on 48 ports
- 30 W of PoE+ on 12 ports
- Total power budget can be allocated among the ports

On a per-port basis, you control whether or not a port automatically provides power when an IP phone or an access point is connected.

The PoE ports use RJ-45 connectors with Ethernet pinouts. The maximum cable length is 328 feet (100 meters). The 10BASE-T, 100BASE-TX, 1000BASE-T traffic requires Category 5, Category 5e, or Category 6 unshielded twisted pair (UTP) cable. The 10BASE-T traffic can use Category 3 or Category 4 UTP cable.

Cisco intelligent power management capabilities include enhanced power negotiation, power reservation, and per-port power policing. For information about configuring and monitoring PoE ports, see the switch software configuration guide on Cisco.com.

**Note**

The output of the PoE circuit has been evaluated as a Limited Power Source (LPS) per IEC 60950-1.

10/100/1000 Ports

The 10/100/1000 ports use RJ-45 connectors with Ethernet pinouts. The maximum cable length is 328 feet (100 meters). The 10BASE-T, 100BASE-TX, 1000BASE-T traffic requires Category 5 or Category 5e twisted pair (UTP) cable. The 10BASE-T traffic can use Category 3 or Category 4 UTP cable.

Related Topics

[10/100/1000 Port Connections](#)

Management Ports

The management ports connect the switch to a PC running Microsoft Windows or to a terminal server.

- Ethernet management port.
- RJ-45 console port (EIA/TIA-232).

- USB mini-Type B console port (5-pin connector).

The 10/100 Ethernet management port connection uses a standard RJ-45 crossover or straight-through cable. The RJ-45 console port connection uses the supplied RJ-45-to-DB-9 female cable. The USB console port connection uses a USB Type A to 5-pin mini-Type B cable. The USB console interface speeds are the same as the RJ-45 console interface speeds.

If you use the USB mini-Type B console port, the Cisco Windows USB device driver must be installed on any PC connected to the console port (for operation with Microsoft Windows). Mac OS X or Linux do not require special drivers.

The 4-pin mini-Type B connector resembles the 5-pin mini-Type B connectors. They are not compatible. Use only the 5-pin mini-Type B.

Figure 3: USB Mini-Type B Port

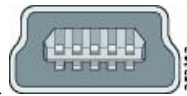

This illustration shows a 5-pin mini-Type B USB port.

With the Cisco Windows USB device driver, you can connect and disconnect the USB cable from the console port without affecting Windows HyperTerminal operations.

The console output always goes to both the RJ-45 and the USB console connectors, but the console input is active on only one of the console connectors at any one time. The USB console takes precedence over the RJ-45 console. When a cable is connected into the USB console port, the RJ-45 console port becomes inactive. Conversely, when the USB cable is disconnected from the USB console port, the RJ-45 port becomes active.

You can use the command-line interface (CLI) to configure an inactivity timeout which reactivates the RJ-45 console if the USB console has been activated and no input activity has occurred on the USB console for a specified time.

After the USB console deactivates due to inactivity, you cannot use the CLI to reactivate it. Disconnect and reconnect the USB cable to reactivate the USB console. For information on using the CLI to configure the USB console interface, see the software guide.

USB Type A Port

The USB Type A port provides access to external USB flash devices (also known as thumb drives or USB keys).

The port supports Cisco USB flash drives with capacities from 128 MB to 8 GB (USB devices with port densities of 128 MB, 256 MB, 1 GB, 4 GB, and 8 GB are supported). When combined with stacking, you can upgrade other switches in the stack from an USB key inserted in any switch within the stack. Cisco IOS software provides standard file system access to the flash device: read, write, erase, and copy, as well as the ability to format the flash device with a FAT file system.

It provides you with the ability to automatically upgrade the internal flash with the USB drive's configuration and image for emergency switch recovery using USB auto-upgrade. This feature checks the internal flash for a bootable image and configuration and if either image or the configuration is not available, then the USB drive is checked for boot images and configuration. If the boot image and configuration are available, these are copied to flash for the reboot.

SFP and SFP+ Module Slots

The switch has either two or four 1-Gigabit SFP or two 10-Gigabit SFP+ module slots. The slots marked *SFP+* support both SFP and SFP+ modules. The *SFP* slots support only the SFP modules.

For Cisco SFP and SFP+ modules documentation, including compatibility matrixes, refer to this URL: http://www.cisco.com/en/US/products/hw/modules/ps5455/products_device_support_tables_list.html

LEDs

You can use the switch LEDs to monitor switch activity and its performance.

Figure 4: Switch LEDs and Mode Button for the Catalyst 2960-X Switch

This figure shows the switch LEDs and the Mode button that you use to select a port

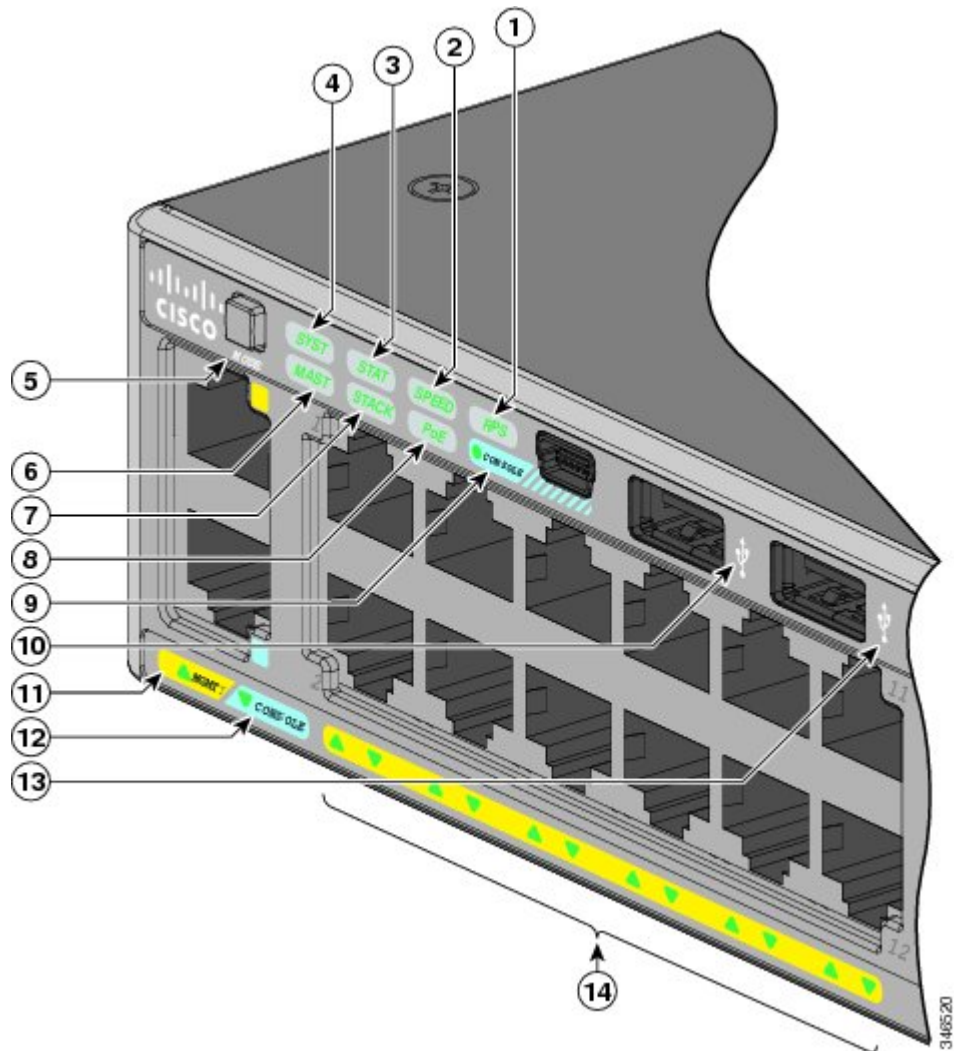

mode.

1	RPS LED ⁴	8	PoE LED
---	----------------------	---	---------

2	SPEED LED	9	USB mini-Type B console port LED
3	STAT LED	10	USB Type A port
4	SYS LED	11	MGMT LED
5	Mode button	12	CONSOLE LED
6	Master LED ⁶	13	USB Type A port
7	STACK LED	14	Port LEDs

⁴ RPS = redundant power system—only on switch models that support RPS.

⁵ Only on switch models that support PoE.

⁶ Only on switch models that support stacking.

Figure 5: Switch LEDs and Mode Button for the Catalyst 2960-XR Switch

This figure shows the switch LEDs and the Mode button that you use to select a port

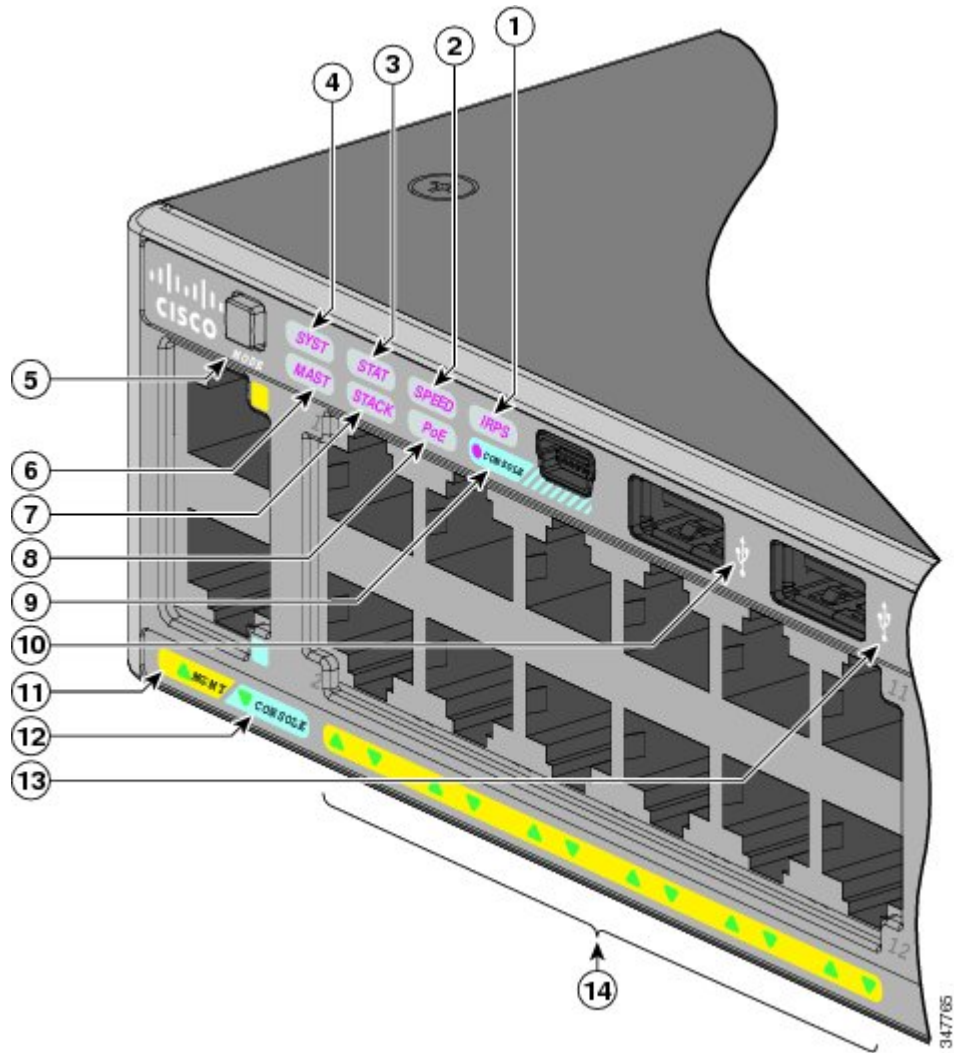

mode.

1	IRPS LED	8	PoE LED ⁷
2	SPEED LED	9	USB mini-Type B console port LED
3	STAT LED	10	USB Type A port
4	SYS LED	11	MGMT LED
5	Mode button	12	CONSOLE LED
6	Master LED ⁸	13	USB Type A port
7	STACK LED	14	Port LEDs

⁷ Only on switch models that support PoE.

⁸ Only on switch models that support stacking.

System LED

Table 3: System LED

Color	System Status
Off	System is not powered on.
Green	System is operating normally.
Blinking green	POST in progress.
Amber	System is receiving power but is not functioning properly.
Blinking amber	System is sleep mode.

RPS LED

The RPS LED is only available on switch models that have an RPS port . This is available only on the Catalyst 2960-X switches.



Note RPS is not supported on the Catalyst 2960-X 24PSQ-L switches.

Table 4: RPS LED

Color	RPS Status
Off	RPS is off or not properly connected.
Green	RPS is connected and can provide back-up power.
Blinking green	RPS is connected but is unavailable. It is providing power to another device (redundancy has been allocated to the other device).
Amber	The RPS is in standby mode or in a fault condition. See the RPS documentation.
Blinking amber	The power supply in a switch has failed, and the RPS is providing power to the switch (redundancy has been allocated to this device).

IRPS LED

The IRPS LED is only available on Catalyst 2960-XR switches.

Table 5: IRPS LED

Color	RPS Status
Off	Second power supply is not present.
Green	Both power supplies are present and operating.
Amber	The second power supply is present, but the input is not connected.
Blinking amber	The second power supply is present, but the signal is faulty.

Master LED

This table describes the master LEDs.

Table 6: Master LED

Port Mode	Description
Off	Switch is not the stack master.
Green	Switch is the stack master or a standalone switch.
Amber	An error occurred when the stack was electing the stack master switch, or another type of stack error occurred.

Port LEDs and Modes

The port and module slots each has a port LED. As a group or individually, the LEDs show information about the switch and about the ports.

Table 7: Port Mode LEDs

Mode LED	Port Mode	Description
STAT	Port status	The port status. This is the default mode.
SPEED	Port speed	The port operating speed: 10, 100, 1000 Mb/s, or 10 Gb/s.
STACK	Stack member status Stack port status	The stack member status. The stack port status.
PoE	PoE port power	The PoE status.

To select or change a mode, press the Mode button until the desired mode is highlighted. When you change port modes, the meanings of the port LED colors also change.

Table 8: Meanings of LED Colors in Different Modes

Port Mode	Port LED Color	Meaning
PoE	Off	PoE is off. If the powered device is receiving power from an AC power source, the port LED is off even if the powered device is connected to the switch port.
	Green	PoE is on. The port LED is green only when the switch port is providing power.
	Alternating green and amber	PoE is denied because providing power to the powered device will exceed the switch power capacity.
	Blinking amber	PoE is off due to a fault. Noncompliant cabling or powered devices can cause a PoE port fault. Use only standard-compliant cabling to connect Cisco prestandard IP Phones and wireless access points or IEEE 802.3af-compliant devices. You must remove any cable or device that causes a PoE fault.
	Amber	PoE for the port is disabled. (PoE is enabled by default.)

Port Mode	Port LED Color	Meaning
STAT (port status)	Off	No link or port was administratively shut down.
	Green	Link present.
	Blinking green	Activity. Interface is sending or receiving data.
	Alternating green-amber	Link fault. Error frames can affect connectivity, and errors such as excessive collisions, cyclic redundancy check (CRC) errors, and alignment and jabber errors are monitored for a link-fault indication.
	Amber	Port is blocked by Spanning Tree Protocol (STP) and is not forwarding data. After a port is reconfigured, the port LED can remain amber for up to 30 seconds as STP searches the switch for possible loops.
Blinking amber	Port is blocked by STP and is sending and receiving packets.	

Port Mode	Port LED Color	Meaning
SPEED	10/100/1000 ports	
	Off	Port is operating at 10 Mb/s.
	Green	Port is operating at 100 Mb/s.
	Blinking green	Port is operating at 1000 Mb/s.
	SFP module ports	
	Off	Port is operating at 10 Mb/s.
	Green	Port is operating at 100 Mb/s.
	Blinking green	Port is operating at 1000 Mb/s.
	SFP+ module ports (Applies to the Catalyst 2960X-48FPD-L, 2960X-48LPD-L, 2960X-24PD-L, 2960X-48TD-L, and the 2960X-24TD-L switches.)	
	SFP+ module ports (Applies to the Catalyst 2960XR-48FPD-I, 2960XR-48LPD-I, 2960XR-24PD-I, 2960XR-48TD-I, and the 2960XR-24TD-I switches.)	
	Off	Port is not operating.
	Blinking green	Port is operating at 10 Gb/s.
	Green	Port is operating at 1 Gb/s.
STACK (stack member)	Off	No stack member has that member number.
	Blinking green	Stack member number.
	Green	Member numbers of other stack member switches.

If your switches are stacked and you press the Mode button on any switch, all the switches display the same selected mode. For example, if you press the Mode button on the stack master to display SPEED, all the other stack members display SPEED.

Even if PoE mode is not selected, this LED still shows PoE problems if they are detected.

STACK LED

The STACK LED shows the sequence of member switches in a stack. Up to eight switches can be members of a stack. The first eight port LEDs show the switch member number. For example, if you press the Mode button and select Stack, the port LED 1 blinks green. The LEDs for port 2 and 3 are solid green, as these represent the member numbers of other stack members. The other port LEDs are off because there are no more members in the stack.

Figure 6: STACK LED

This figure shows the LEDs on the first switch, which is stack member number 1.

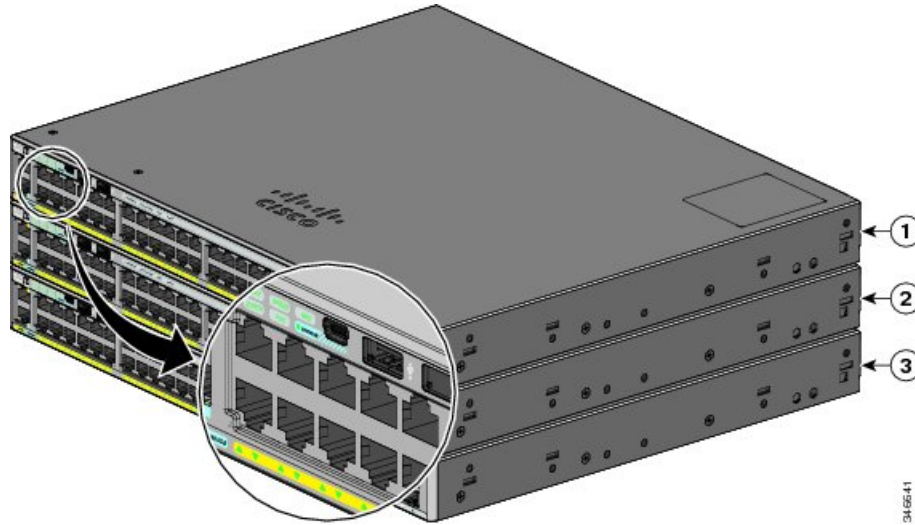

1	Stack member 1	3	Stack member 3
2	Stack member 2		

When you select the STACK LED, the respective STACK LEDs are green when the stack ports (on the switch rear panel) are up, and the respective Stack LEDs are amber when the ports are down. SFP+ module port LEDs 1 and 2 on the switch show the status for stack ports 1 and 2, respectively.

If the port LEDs are green on all the switches in the stack, the stack is operating at full bandwidth. If any port LED is not green, the stack is not operating at full bandwidth.

Console LEDs

The console LEDs show which console port is in use. If you connect a cable to a console port, the switch automatically uses that port for console communication. If you connect two console cables, the USB console port has priority.

Table 9: RJ-45 and USB Console LEDs

LED	Color	Description
RJ-45 console port	Green	RJ-45 console port is active. When this LED is on, the USB console port LED is off.
	Off	The port is not active, and the USB console port is active.

LED	Color	Description
USB console port	Green	USB console port is active. When this LED is on, the RJ-45 console port LED is off.
	Off	The port is not active, and the RJ-45 console port is active.

Ethernet Management Port LED

Table 10: Ethernet Management Port LED

Color	Description
Green	Active link to PC.
Off	Inactive link.
Amber	POST failure.

Rear Panel

The rear panel of the Catalyst 2960-X switches have a FlexStack module slot, a fan exhaust, an RPS connector, and an AC power connector.



Note The FlexStack module slot is not available on the Catalyst 2960X-48TS-LL and 2960X-24TS-LL switches. The FlexStack module slot, fan exhaust, and the RPS connector are not available on the Catalyst 2960-X 24PSQ-L switch.

Figure 7: Catalyst 2960-X Switch Rear Panel

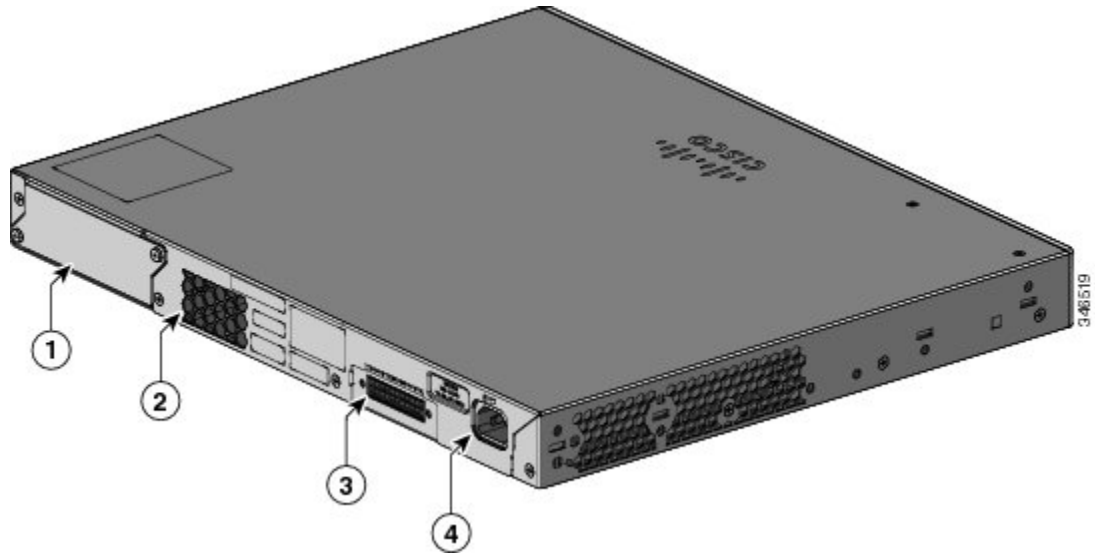

1	FlexStack module slot and cover	3	RPS Connector
2	Fan Exhaust	4	AC power connector

The rear panel of the Catalyst 2960-XR switches have a FlexStack module slot and power supply module slots.

Figure 8: Catalyst 2960-XR Switch Rear Panel

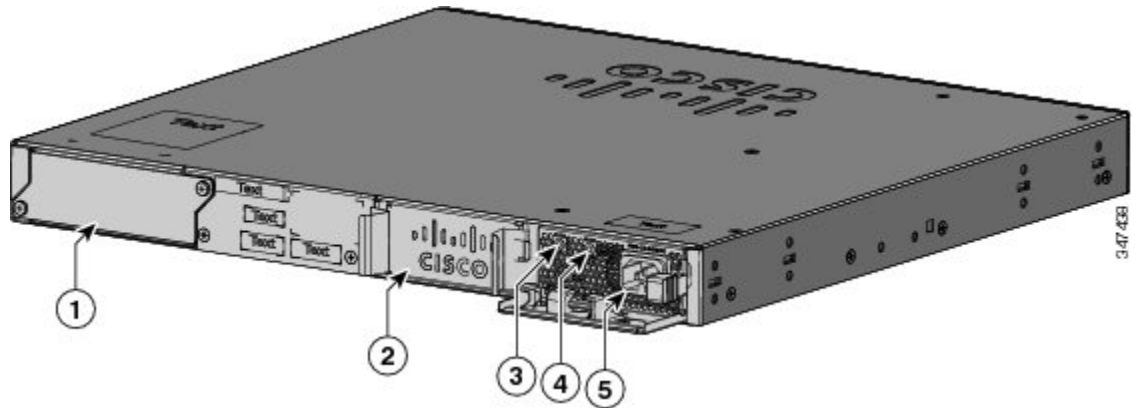

1	FlexStack module slot and cover	4	PS OK LED
2	Power supply slot (with blank module)	5	AC power connector on the power supply module
3	AC OK LED		

FlexStack Ports and LEDs

FlexStack-Plus Ports and LEDs

The stacking-capable switch models support stacking with the optional stack kit. It has the FlexStack-Plus module (hot-swappable) that inserts in the slot located in the switch rear panel, and a 0.5-meter FlexStack cable to connect the FlexStack-Plus module ports.

Figure 9: FlexStack-Plus Module

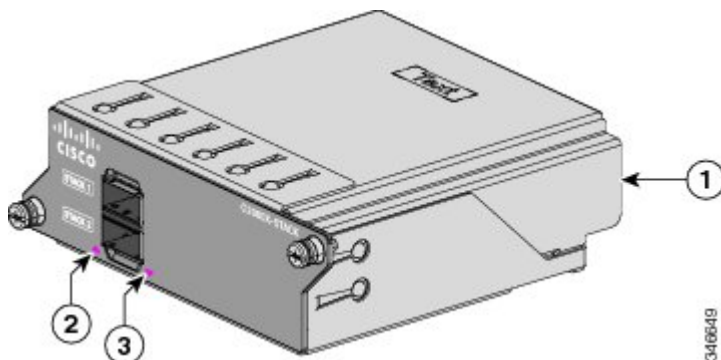

1	FlexStack-Plus module	3	LED for Stack port 2
2	LED for Stack port 1		

This table lists the FlexStack-Plus module LED colors and their meanings.

Table 11: FlexStack-Plus Module LEDs

Color	Description
Green	Port is active, cable is attached.
Off	The port is not active, no cable is attached.

Table 12: Stack Configurations

Switch	Number of Switches in the Stack	Bandwidth
Stack with Catalyst 2960-X stack-capable switches	8	80 G
Stack with Catalyst 2960-XR stack-capable switches	8	80 G
Mixed stack with Catalyst 2960-S and Catalyst 2960-X stack-capable switches	4	40 G

FlexStack-Extended Ports and LEDs

FlexStack-Extended Fiber Module

The FlexStack-Extended Fiber Module (C2960X-FIBER-STK) is used to stack switches across wiring closets on different floors of a building or across different buildings in a campus. The module allows stacking over SFP+ module ports and provides bandwidth of up to 40 Gpbs over longer distance. The FlexStack-Extended Fiber module has two SFP+ module ports. The SFP+ port enables long-reach stacking using standard multimode LR (300m) and EX (7km) optics. You should select the appropriate SFP+ module depending on the distance required between the switches.

For more information about the SFP+ transceiver modules supported on FlexStack ports, see [Compatibility Matrix](#).

Figure 10: FlexStack-Extended Fiber Module

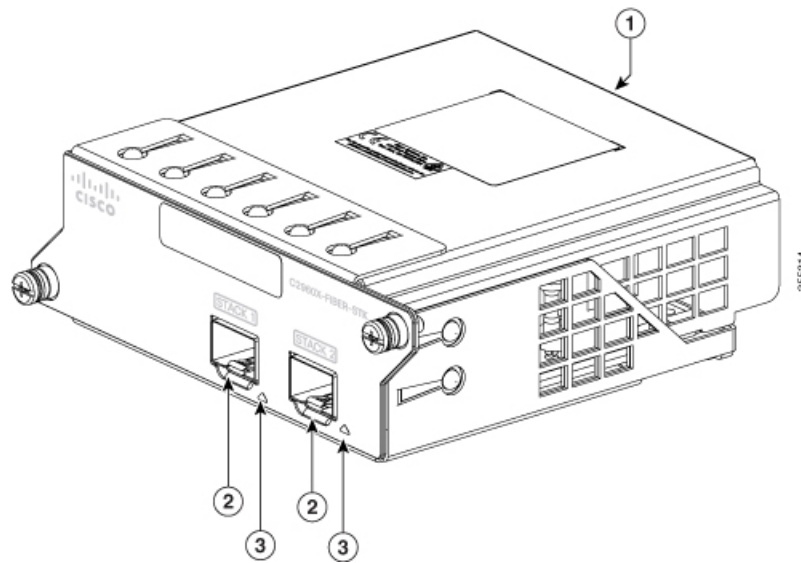

1	FlexStack-Extended Fiber module	3	LEDs for SFP+ module ports
2	SFP+ module ports		

FlexStack-Extended Hybrid Module

The Cisco FlexStack-Extended Hybrid module (C2960X-HYBRID-STK) has one SFP+ port and one copper FlexStack-Plus port. The copper port enables short-reach connectivity across a local stack of switches. The SFP+ port enables long-reach stacking using standard multimode LR (300m) and EX (7km) optics. You can choose the appropriate SFP+ depending on the distance between the switches.

For more information about the SFP+ transceivers supported on the FlexStack ports, see [Compatibility Matrix](#).

The copper FlexStack-Plus port allows the switch to stack with the Cisco FlexStack-Plus stacks. You can only stack Cisco Catalyst 2960-X or Cisco Catalyst 2960-XR switches. FlexStack cables of following lengths are supported.

- CAB-STK-E-0.5M= (0.5-meter cable)

- CAB-STK-E-1M= (1-meter cable)
- CAB-STK-E-3M= (3-meter cable)

Figure 11: FlexStack-Extended Hybrid Module

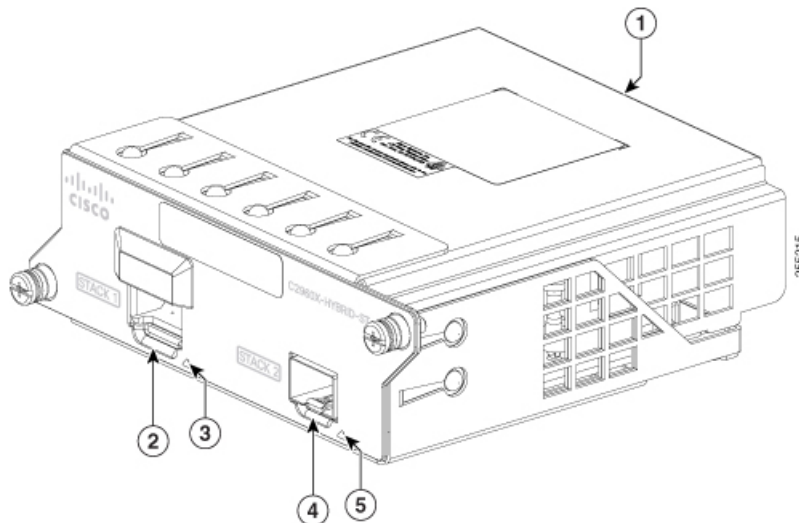

1	FlexStack-Extended Hybrid module	4	Fiber SFP+ module port
2	Copper FlexStack-Plus port	5	LED for Fiber SFP+ module port
3	LED for Copper FlexStack-Plus port		

This table lists the FlexStack-Extended module LED colors and their meanings.

Table 13: FlexStack-Extended Module LEDs



Color	Description
 Green	Port link is up, but there is no packet activity.
	Port link is up and packet activity is present.
Off	Port link is down.

Table 14: Stack Configurations

Switch	Number of Switches in the Stack	Bandwidth
Stack with Catalyst 2960-X stack-capable switches	8	40 G

Switch	Number of Switches in the Stack	Bandwidth
Stack with Catalyst 2960-XR stack-capable switches	8	40 G

RPS Connector

The Cisco RPS 2300 (model PWR-RPS2300) supports the Catalyst 2960-X switch.



Note RPS is not supported on the Catalyst 2960-X 24PSQ-L switches.



Warning Attach only the following Cisco RPS model to the RPS receptacle: RPS2300. Statement 370

Connect the switch and the redundant power system to different AC power sources.

Use this cable for the RPS: CAB-RPS2300-E.

Cisco RPS 2300

The Cisco RPS 2300 is a redundant power system that can support six external network devices and provide power to one or two failed devices at a time. It senses when the internal power supply of a connected device fails and provides power to the failed device, preventing loss of network traffic. For more information, see the *Cisco Redundant Power System 2300 Hardware Installation Guide* on Cisco.com at this URL: http://www.cisco.com/en/US/products/ps7148/prod_installation_guides_list.html

The Cisco RPS 2300 has two output levels: -52 V and 12 V with a total maximum output power of 2300 W.

All supported and connected switches can simultaneously communicate with the RPS 2300. You can configure these RPS 2300 features through the switch software:

- Enable RPS active or standby mode for each connected switch
- Configure switch priority for RPS support
- List the connected switches and the power-supply module sizes
- Obtain reports when a switch is powered by the RPS
- Obtain status reports for the RPS power-supply module
- Read and monitor backup, failure, and exception history

AC Power Connector



Note This applies to the Catalyst 2960-X switches.

The switch is powered through the internal power supply. The internal power supply is an autoranging unit that supports input voltages between 100 and 240 VAC. Use the supplied AC power cord to plug it into an AC power outlet.

Power Supply Modules (Applies to the Catalyst 2960-XR Switches)

The switch operates with either one or two active power supply modules. You can use two AC modules, or one module and a blank cover.



Note The Catalyst 2960XR-48FPD-I and 2960XR-48FPS-I only support the PWR-C2-1025WAC power supply. You cannot use the PWR-C2-250WAC and PWR-C2-640WAC power supplies in these switches.

Table 15: Power Supply Model Numbers and Description

Part Number	Description
PWR-C2-250WAC=	250-W AC power supply module.
PWR-C2-640WAC=	640-W AC power supply module.
PWR-C2-1025WAC=	1025-W AC power supply module.

The 250-W and 640-W AC power supply modules are autoranging units that support input voltages between 100 and 240 VAC. The 1025-W power supply module is an autoranging unit that supports input voltages between 115 and 240 VAC. All power supply modules have internal fans. All switches ship with a blank cover in the second power supply slot.

Table 16: Available PoE with Different Combinations of Power Supplies

Primary Power Supply	Secondary Power Supply	Available Power for PoE+	Switch Power Redundancy	Available PoE Power when One PS Fails
PWR-C2-250WAC=	—	0	No	—
PWR-C2-250WAC=	PWR-C2-250WAC=	0	Yes	—
PWR-C2-640WAC=	—	370 W	No	—
PWR-C2-640WAC=	PWR-C2-640WAC=	370 W	Yes	370 W
PWR-C2-1025WAC=	—	740 W	No	—
PWR-C2-1025WAC=	PWR-C2-1025WAC=	740 W	Yes	740 W

Management Options

- Cisco Network Assistant

Cisco Network Assistant is a PC-based network management GUI application for LANs of small and medium-sized businesses. You can use the GUI to configure and manage switch clusters or standalone switches. Cisco Network Assistant is available at no cost and can be downloaded from this URL: <http://www.cisco.com/en/US/products/ps5931/index.html>

For information on starting the Network Assistant application, see the *Getting Started with Cisco Network Assistant* guide on Cisco.com.

- Device Manager

You can use Device Manager in the switch memory to manage individual and standalone switches. This web interface provides configuration and monitoring from anywhere in your network. For information, see the switch getting started guide and the Device Manager online help.

- Cisco IOS CLI

You can configure and monitor the switch and switch cluster members from the CLI. Access the CLI by connecting your management station to the switch console port or by using Telnet from a remote management station. See the switch command reference on Cisco.com for information.

- Cisco Prime Infrastructure

Cisco Prime Infrastructure combines the wireless functionality of Cisco Prime Network Control System (NCS) and the wired functionality of Cisco Prime LAN Management Solution (LMS), with application performance monitoring and troubleshooting capabilities of Cisco Prime Assurance Manager. For more information, see the Cisco Prime Infrastructure documentation on Cisco.com.

- Catalyst Smart Operations

The Smart Install feature provides a single point of management (director) in a network. You can use it to provide a zero touch image and configuration upgrade of newly deployed switches and image and configuration downloads for any client switches. For information, see the *Cisco Smart Install Configuration Guide* on Cisco.com.

Auto Smartports macros dynamically configure ports based on the device type detected on the port. When the switch detects a new device, it applies the appropriate Auto Smartports macro on the port. For information about configuring Auto Smartports, see the switch software configuration guide on Cisco.com.

Network Configurations

See the switch software configuration guide for network configuration concepts and examples of using the switch to create dedicated network segments and interconnecting the segments through Fast Ethernet and Gigabit Ethernet connections.

